

Owners manual

Öhlins road & track front fork Ø 43

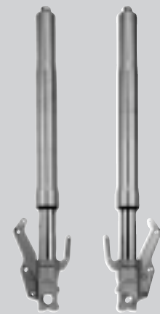

Including:
**Setting up
your fork**

**Changing
springs
and seals**

**Service
the fork**

**Trouble
shooting**

**Technical
info**

**Spare parts
& tools**

Traction, handling,
comfort and safety



ADVANCED SUSPENSION TECHNOLOGY

Öhlins road & track front fork Ø 43

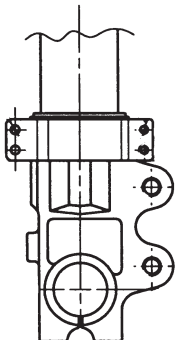

Contents

Introduction	2
Setting up your forks	
Spring preload adjustment	3
Rebound adjustment	
Compression adjustment	
Changing springs	
Changing seals	
Dismantling the forks	4
Assembling the forks	
Trouble shooting	
Oil level adjustment	5
Technical information	
Spare parts	6
Tools	

Safety signals

Important information concerning safety is distinguished in this manual by the following notations



The Safety alert symbol means:
Caution! Your safety is involved.

WARNING!

Failure to follow warning instructions could result in **severe or fatal injury** to anyone working with, inspecting or using the suspension, or to bystanders.

CAUTION!

Caution indicates that special precautions must be taken to avoid damage to the suspension.

NOTE!

This indicates information that is of importance with regards to procedures

Kit contents

Before installing the suspension, please check the contents of the kit, listed on the front page of this instruction. If anything is missing, contact your Öhlins dealer.

NOTE!

During storage and transportation, especially at high ambient temperature, the oil and grease used for assembling may run out inside the packing and damage the expanded polystyrene packing material. This is not unusual and is in no way detrimental to the suspension.

Before you start

WARNING!

Installing a suspension, that is not approved by the vehicle manufacturer, may affect the stability of your vehicle. Öhlins Racing AB cannot be held responsible for any personal injury or damage whatsoever that may occur after fitting the suspension. Contact an Öhlins dealer or other qualified person for advice.

Öhlins Racing AB can not be held responsible for any damage whatsoever to suspension or vehicle, or injury to persons, if the instructions for fitting and maintenance are not followed exactly. Similarly, the warranty will become null and void if the instructions are not adhered to.

WARNING!

Please study and make certain that you fully understand all the mounting instructions and the owner's manuals before handling this suspension kit. If you have any questions regarding proper installation procedures, contact an Öhlins dealer or other qualified person.

WARNING!

The vehicle service manual must be referred to when installing the Öhlins suspension.

NOTE!

Öhlins products are subject to continual improvement and development. Consequently, although these instructions include the most up-to-date information available at the time of printing, there may be minor differences between your suspension and this manual. Please consult your Öhlins dealer if you have any questions with regard to the contents of the manual.

NOTE!

Make sure that all bolts are tightened to the correct torque and that nothing fouls or restricts movement of the suspension when it's being fully compressed or extended

© Öhlins Racing AB.
All rights reserved.

Any reprinting or unauthorized use without the written permission of Öhlins Racing AB is prohibited.
Printed in Sweden.

Introduction

The Öhlins front forks use a cartridge system for damping. This gives a damping force which depends on the speed of the piston in the cartridge system.

The combination of spring and air volume (oil level) gives a possibility to adjust the characteristics of the fork to suit different tracks and riders.

For example a soft spring in combination with a small air volume (high oil level) gives progressive action of the front forks.

For better understanding, please refer to our oil level chart.

A telescopic front fork depends on smooth friction-free action.

Make sure your front forks are serviced regularly and don't use strong solvents such as brake cleaner to clean the front forks. This will dry out the seals and steel tubes and cause friction.

Put a little Öhlins grease (148-01) regularly on the steel tube and work it in by pushing the forks up and down.

Setting up your forks

Here are some basic guidelines for setting up your Öhlins front forks. However, you must remember that the front forks are just one part of your motorcycle and to get it to work properly, the whole motorcycle has to be set up in conformance with its manual.

1

Put your bike on a front stand so you can fit the front forks.

Maximum torque on the bottom triple clamp and steering damper bracket (if it is located on the diameter of the outer tube) is 15-18 Nm.

Dismantle the front wheel and brakes.

2

Unscrew the adjustment housing on top of the fork (use tool 4703-01) on both upper tubes and slide the fork up and down gently to make sure everything works correctly.

3

Assemble the adjustment housing again and set your initial preload of the spring by using a 12 mm wrench until you get a "static sag" of 25-30 mm.

Each turn gives 1 mm in preload. Maximum preload is 18 mm.

4

The best way to check the "static sag" is to put the bike on the ground in running condition. Measure the distance between the bottom of the outer tube

to the fork bottom. Then lift the front end of the bike, so the fork is fully extended. Measure again. The difference between these two figures is the "static sag".

5

The "clicks" are a "bleed function", separate for rebound and compression damping. Rebound adjustment is made on the top centre of the fork and compression adjustment at the bottom part of the fork.

You start to count from fully closed (clockwise) and set it to the recommended "click" (use a 3 mm Allen key). For recommended start setting, please refer to the mounting instruction.

Spring preload adjustment

Using a 12 mm wrench, turn the upper adjustment screw.

Maximum adjustment range is 18 mm. One turn of the adjustment screw will cause 1 mm change in spring preload. Adjust so the front forks are lowered 25-30 mm from the top, unloaded position.

Rebound adjustment

Adjust the rebound rate on the adjustment screws positioned at the top centre of the front forks. Use a hex key with a spherical head (use tool 794-01).

Adjustment range from closed valve (clockwise) to maximum open valve (anticlockwise) is 20 "clicks". See mounting instruction for recommended adjustment "clicks", from closed position.

Compression adjustment

Adjust the compression rate on the lower part of the front forks (compression valve). Use a hex key with spherical head (use tool 794-01).

Adjustment range from closed valve (clockwise) to maximum open valve (anticlockwise) is 20 "clicks". See mounting instruction for recommended adjustment "clicks", from closed position.

Changing springs

1

Loosen the screws that hold the fork legs in the upper triple clamps.

2

Loosen the adjustment housings (item A, page 6) about two turns (use tool 4703-01).

3

Remove the fork legs from the motorcycle.

4

Grip a fork leg in a vice. Use soft jaws.

5

Unload the spring completely by turning the adjustment screw anticlockwise. Use a 12 mm wrench.

6

CAUTION!

Do not damage the O-ring and do not drop the flat key into the fork leg. Carefully remove the adjustment housing.

7

Remove the preload tube and spring. (Free spring length; see page 5).

8

Pull out the piston rod as far as possible and turn the compression adjustment screw fully clockwise. This will keep the piston rod in top position, which will make the continued assembly easier.

9

Install the new spring and preload tube.

10

Install the adjustment housing.

CAUTION!

The flat key must be guided in the slot of the adjustment housing.

11

Fasten the adjustment housing in the fork leg. Make sure that the fork leg is fully extended when tightening the adjustment housing.

12

Install the fork legs on the motorcycle and adjust the preload, compression and rebound according to the instructions above.

Changing seals

Put the fork legs upright for 15 minutes.

1

Grip the fork leg in a vice. Use soft jaws.

2

Unload the spring preload completely by turning the adjustment screw anticlockwise. Use a 12 mm wrench.

Make a note of the number of turns.

3

Carefully remove the adjustment housing.

CAUTION!

Do not damage the O-ring and do not drop the flat key into the fork leg.

4

Remove the preload tube.

5

Slide the outer fork leg up until the top bushing is just above the inner leg. (Approx. 140 mm from complete bottom position. This is to make sure there is no oil above the top bushing).

6

Slide the outer tube completely down. (Fork seal touching fork bottom).

7

Push the piston rod down completely.

NOTE!

When measuring the oil level, always have the spring installed.

Measure the oil level using the top of the outer tube as the zero mark.

Note the measurement.

8

Remove the spring and tip the oil in a clean container.

9

Remove the outer tube, clean the seals and check for damage, if the seals are damaged remove and replace. If the seals are OK, then apply Öhlins grease (green grease 148-01).

10

Apply Öhlins fork oil on the seals and on the inner tube.

11

Carefully mount outer tube (slide completely down), install spring and set the oil level.

12

Carry on with 9 to 12 according to page 3 "Changing springs".

Dismantling the forks

1

Carry out 1 to 7 of page 3 "Changing springs".

2

Free the fork leg from the vice and drain the oil.

3

Pull up the outer tube and remove the seals.

4

Grip the inner tube on the fork bottom in a vice. Use soft jaws.

5

Unscrew (item 22, page 7) from the

cartridge system (use tool 4702-01) and remove the piston rod unit. Drain the remaining oil.

6

Remove the compression valve assembly.

7

Remove the piston and the shims from the piston rod and compression valve. Place the shims in their correct position on the work bench.

8

Clean all parts thoroughly and dry with compressed air.

Assembling the forks

1

Apply a thin layer of Öhlins green grease (148-01) on the scraper ring and on the sealing surfaces of the fork seal. Install the seals in the outer tube. Please note that it is important to use the correct grease in order to achieve optimum fork function.

2

Install the piston and the shims on the piston rod and the compression valve. Tighten the 8 mm lock nuts with a torque of 8 Nm.

Check the piston ring for damage. Replace if necessary.

3

Install the compression valve assembly into the cartridge system. Assemble the seal head (tool 4702-01). Use: loctite 270 (1791-05) and tighten firmly.

4

Apply some front fork oil 1309-01 on the inner steel tube surface and install the outer aluminium tube. Measure the correct amount of 1309-01 oil according to the mounting instruction.

CAUTION!

Be careful not to damage the fork leg seals.

5

Raise the outer tube approximately 120 mm and fill the oil.

6

Install the cartridge assembly using red grease (146-01) on the thread going into the fork bottom.

7

Pump the piston rod up and down and the oil will be sucked into the cartridge tube. Close the "clickers" and check the function.

8

Pull the piston rod out as far as possible and close the compression valve by screwing fully (clockwise).

9

Carry on with 8 to 12 according to page 3 "Changing springs".

Trouble shooting

Here are a few common Road Racing problems and their solutions.

A

The front wheel "chatters" entering a corner, the problem disappears as soon as you let the brakes off, or when you apply power. The problem is caused by the fact that the fork is working too low in its travel and reaches the progressive, hard part at the end of the travel.

1

Apply more preload.

2

Change to a harder spring.

3

If a lot of stroke remains after riding, lower the oil level. See oil level chart.

4

Make sure the front forks have no friction.

5

Rear ride height is too high, too much rear spring preload.

Lower the rear end by reducing preload on the rear shock spring.

B

The front wheel jumps during the last part of braking.

1

If a lot of stroke remains, the oil level is too high. Lower the oil level.

2

If the fork is bottoming, put in harder springs and keep the same oil level.

C

The front end feels unpredictable and unsafe in the middle of a corner (between braking and applying power).

1

Not enough rebound damping. Apply more damping.

2

Too much rebound damping. If it at the same time feels harsh, lightly reduce the rebound damping.

3

Too much compression damping. Also gives a harsh feeling. Lightly reduce the compression damping.

D

The front end loses grip coming out of a corner.

1

Not enough rebound damping. Lightly increase the rebound damping.

2

Too much preload. Lightly reduce the preload.

3

Rear end is too soft. Put on a harder rear spring.

4

Front end is too high. Lower the front end by pulling the fork legs through the triple clamps.

As mentioned at the beginning, the whole bike setup affects the front forks. Try to understand how the action feels and work step by step.

NOTE!

Our advice is to change only one thing at a time and do everything step by step.

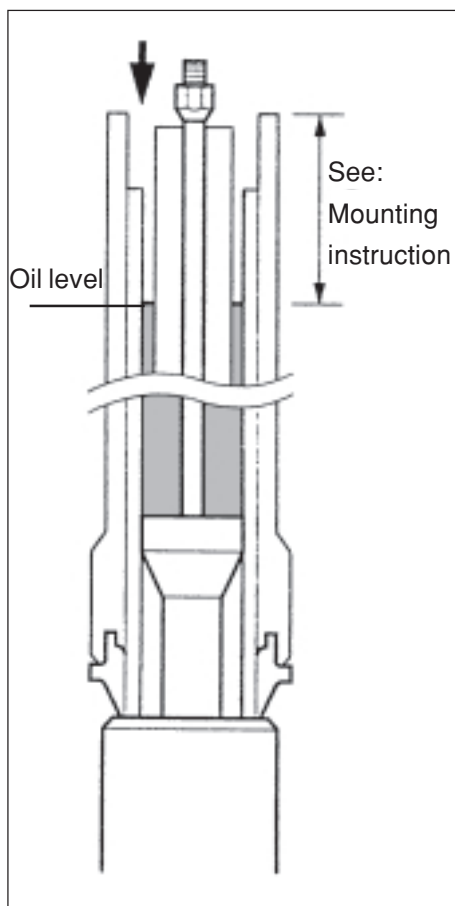

Air spring characteristics

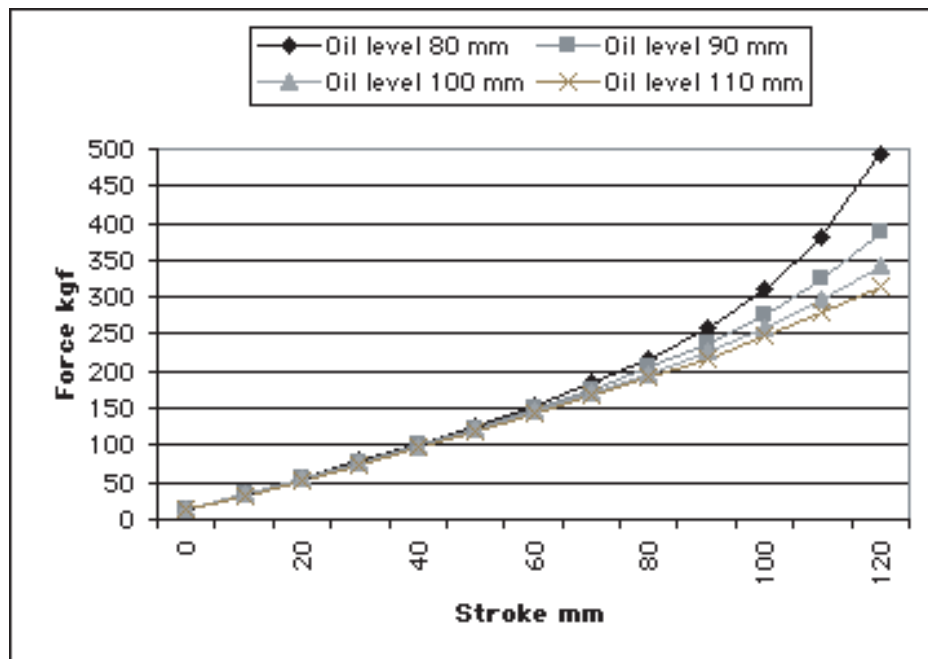

Oil level adjustment

Compared with conventional type of front forks, the upside down front forks are very sensitive to variations in oil level. Therefore, adjust the oil level with special care.

A change in the fork oil level will not affect damping force in the early stage of fork travel, but will have a great effect in the later stage.

When the oil level is raised:

The air spring in the later half stage of travel is stronger, and thus the front forks harder.

When the oil level is lowered:

The air spring in the later half stage of travel is lessened, and thus the front forks are softer. The oil level works most effectively at the end of the fork travel. Air spring characteristics shown, refer to a general card description to facilitate understanding of the difference when the oil level is changed.

NOTE!

Adjust the oil level in mm according to the figure with the fork fully compressed and with the spring mounted. For the right recommended level, please see the mounting instruction.

Technical information

Fork length:

730 mm.

Stroke:

120 mm.

Free spring length:

240 mm.

Rebound adjustment:

Basic setting 9-12 "clicks".

Maximum open valve 20 "clicks".

Compression adjustment:

Basic setting 6-16 "clicks".

Maximum open valve 20 "clicks".

Spring preload adjustment:

0-18 mm (0-18 turns).

Spring rate

4745-95, 9.5 N/mm

Optional springs:

4745-75, 7.5 N/mm (marking -75).

4745-80, 8.0 N/mm (marking -80).

4745-85, 8.5 N/mm (marking -85).

4745-90, 9.0 N/mm (marking -90).

4745-95, 9.5 N/mm (marking -95).

4745-10, 10.0 N/mm (marking -10).

4745-05, 10.5 N/mm (marking -05).

4745-11, 11.0 N/mm (marking -11).

Oil Capacity:

Please see specification card.

CAUTION!

Use only Öhlins high performance front fork fluid (1309-01).

Loctite glue:

542 on Fork Bottom thread.

Tightening torque:

Triple Clamp bolt 15-18 Nm.

Grease:

Öhlins front fork grease 148-01 (green grease).

Spare parts

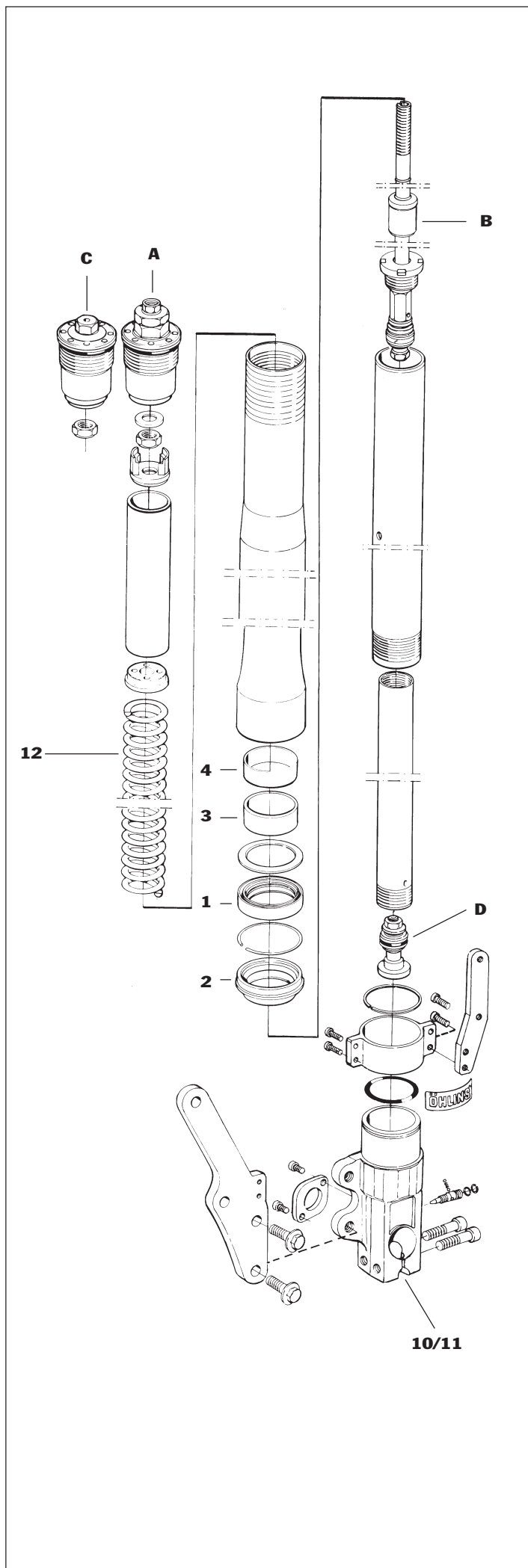
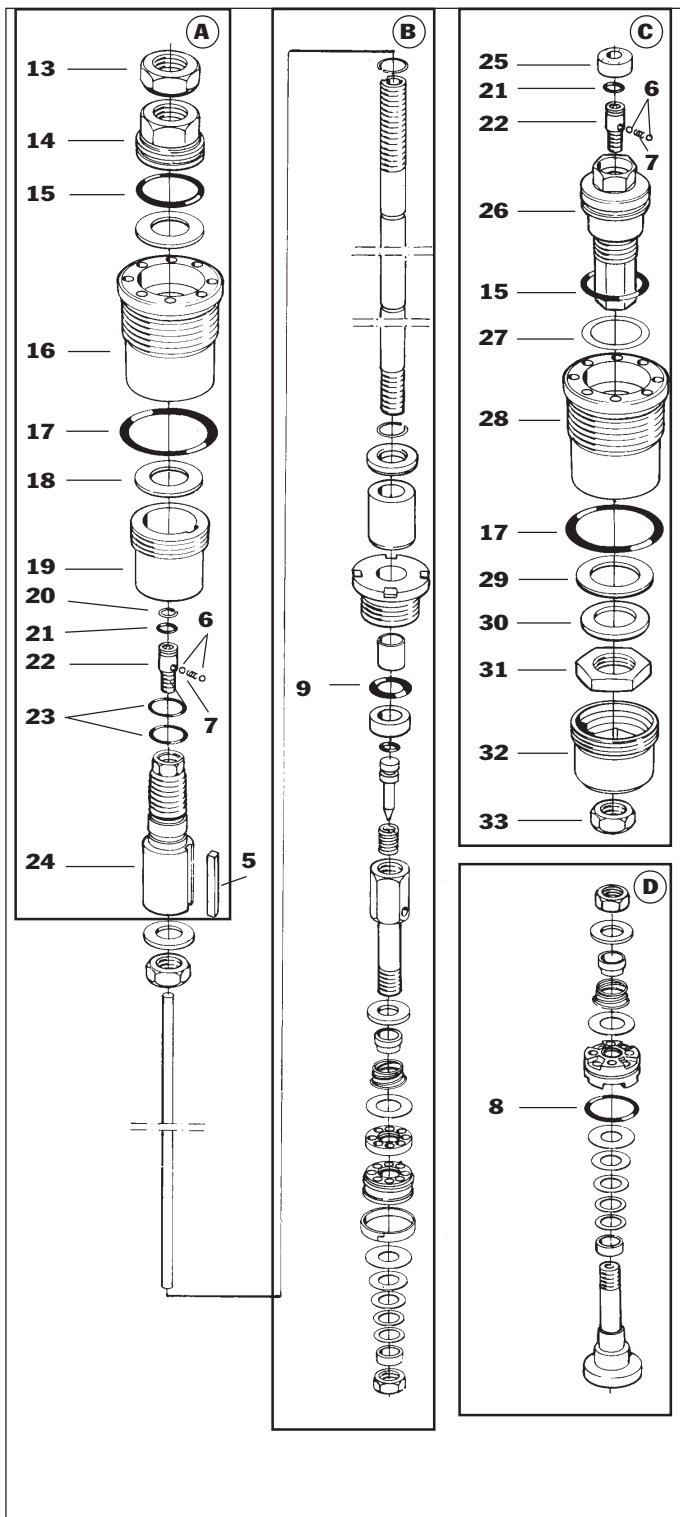

Fig. Part No. Description Pieces

-	04730-01	Seal kit	1
1	04720-01	Seal	2
2	04721-01	Scraper	2
-	04731-01	Repair kit	1
-		Seal kit (see above)	1
3	04724-01	Bushing, lower	2
4	04725-01	Bushing, upper	2
5	04726-01	Key	2
6	00884-04	Ball	4
7	04727-01	Spring	2
8	04722-01	O-ring	2
9	04722-04	O-ring	2
10	04742-01	Fork bottom, right	1
11	04742-02	Fork bottom, left	1
12	04745-75	Spring 7.5 N/mm	
-	04745-80	Spring 8.0 N/mm	
-	04745-85	Spring 8.5 N/mm	
-	04745-90	Spring 9.0 N/mm	
-	04745-95	Spring 9.5 N/mm	
-	04745-10	Spring 10.0 N/mm	
-	04745-05	Spring 10,5 N/mm	
-	04745-11	Spring 11.0 N/mm	



Spare parts

Fig.	Part No.	Description	Pieces
A	04732-01	Top nut assy	1
5	04726-01	Key	1
6	00884-04	Ball	2
7	04727-01	Spring	1
13	04723-01	Nut, hex	1
14	04736-01	Nut	1
15	04722-03	O-ring	1
16	04735-01	Bolt, fork	1
17	04722-05	O-ring	1
18	04738-01	Washer	2
19	04739-01	Screw	1
20	04741-01	Circlip	1
21	04722-04	O-ring	1
22	04755-01	Adjuster	1
23	04722-02	O-ring	2
24	04740-01	Bolt, adjusting	1
C	04732-02	Top nut assy	1
6	00088-04	Ball	2
7	04727-01	Spring	1
15	04722-03	O-ring	1
17	04722-05	O-ring	1
21	04722-04	O-ring	1
25	04746-01	Cap	1
26	04747-01	Bolt sprg. adj.	1
27	04748-01	Plate, center	1
28	04749-01	Bolt fork	1
29	04750-01	Washer	1
30	04751-01	Washer	1
31	04752-01	Nut	1
32	04753-01	Screw	1
33	04754-01	Nut	1

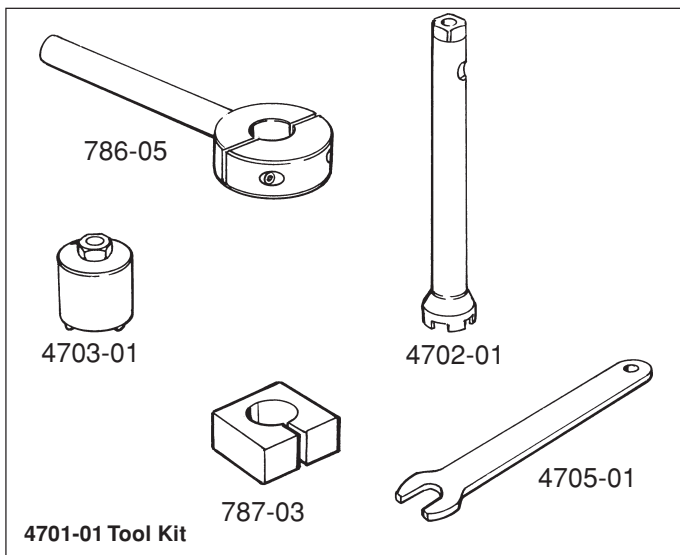

Service tools

Part No.	Description
04701-01	Tool Kit
00787-03	Clamp tool
00786-05	Clamp tool
04702-01	Cartridge tool
04703-01	Top nut tool
04705-01	Top nut holder tool

Öhlins distributors

Motorcycles

AUSTRALIA

Steve Cramer Proucts, BRAESIDE, Tel. +61 3 9587 1466, Fax. +61 3 9587 2018

AUSTRIA

Motopart Handelsges. m.b.H., WIEN, Tel. +43 1 667 6628, Fax. +43 1 667 0696

CANADA

S. Hans Racing Products, EDMONTON, Tel. +1 403 466 8653, Fax. +1 403 465-9483

CROATIA

Moto ZIP trgovina d.o.o., KRANJ, Tel: +386 64 268 515, Fax: +386 64 268 514

DENMARK

F.I. Motorcykler ApS, SORÖ, Tel. +45 57 833 348, Fax. +45 57 834 855

FINLAND

Mauri Penttilä Racing, HYVINKÄÄ, Tel. +358 19 437 100, Fax. +358 19 489 872

FRANCE

P.F.P - Öhlins France, Arpajon-Sur-Cere, Tel. +33 471 481 534, Fax. +33 471 642 593

GERMANY

Zupin Moto-Sport GmbH, TRAUNREUT, Tel. +49 8669 84 82 00, Fax. +49 8669 84 85 93

GREECE

Vassilis Dulaveris, ATHENS, Tel. +30 1-923 6051, Fax. +30 1-924 9957

HONG KONG

Power Motorcycle Specialist, KOWLOON, Tel. +852 3903 949, Fax. +852 3919 434

ICELAND

Baldursson Trading, AKUREYRI, Tel: +354 8545 3136, Fax: +354 462 2777

ITALY

Motorquality S.p.A., SESTO S GIOVANNI (MI), Tel. +39 02 249 511, Fax. +39 02 2495 1232

JAPAN

Carrozzeria Japan Co., Ltd., SAITAMA-PREF; 336, Tel. +81 48 863 1801, Fax. +81 48 863 1802

The NETHERLANDS, BELGIUM, LUXEMBURG

Wim Kroon Import V.O.F., HV MILL, Tel. +31 485 453 911, Fax. +31 485 454 848

NORWAY

MC-Specialisten, SKÅRER, Tel. +47 67 920 380, Fax. +47 67 972 855

NEW ZEALAND

Hawera Motorcycles LMVD, HAWERA TARNAKI, Tel.+64 627 84160, Fax. +64 627 86552

POLAND

P.T.M. SP. zo.o., NIEPORET, Tel. +48 22 774 8978, Fax. +48 22 774 8978

PORTUGAL

Motoni, AMADORA, Tel. +351 1 472 8160, Fax. +351 1 471 4809

RUSSIA

Alpine Ltd, MOSCOW 121 552, Tel. +7 95 149 5069, Fax. +7 95 141 2310

SINGAPORE

Sporting Motorcycles, SINGAPORE 1232, Tel. +65 250 5508, Fax. +65 253 6312

SLOVENIA

Moto ZIP trgovina d.o.o., KRANJ, Tel: +386 64 26 85 15, Fax: +386 64 26 85 14

SOUTH AFRICA

Technical Motor Products, MIDRAND, Tel. +27 11 805 2471, Fax. +27 11 315 0472

SPAIN

Zacatin S.A., TORREJON DE ARDOZ, Tel. +34 1 677 7897, Fax. +34 1 677 6123

SWITZERLAND

3W Motorsport, WINTERTHUR, Tel. +41 52 315 3188, Fax. +41 52 315 3754

TAIWAN

Henly Company Ltd, TAIPEI 10422, Tel. +886 2 5375 600, Fax. +886 2 5631 357

U.K.

Harris Performance Prod. Ltd., HERTFORD, Tel. +44 1992 551 026, Fax. +44 1992 587 052

USA and CANADA

LeMans Corporation, JANESVILLE, WI 53547, Tel. +1 608 758 1111, Fax. +1 608 758 1144

service

Petterson Pro Suspension, ANAHEIM, CA 92807, Tel. +1 714 630 4777, Fax. +1 714 630 4788

service

TUF Racing Products, DEKALB, IL 60115, Tel. +1 815 756 3588, Fax. +1 815 756 3528

(MX & Enduro steeringdampers)

Scotts Performance MC Products, MONTROSE, Tel. +1 818 248 6747, Fax. +1 818 248 4529

Öhlins Authorized Dealers in SWEDEN

Claessons Motor AB, Bromölla, Tel. 0456-230 30, Fax. 0456-232 31

R G Motor AB, Helsingborg, Tel. 042-16 96 60, Fax. 042-16 18 15

DML Pro Bike, Värnamo, Tel. 0370-271 00, Fax 0370-271 61

LEJ Motor AB, Skövde, Tel. 0500-48 11 95, Fax. 0500-46 17 14

Carlmarks Motor AB, Kumla, Tel. 019-57 07 01, Fax. 019-58 12 74

Beviks Motor AB, Linköping, Tel. 013-36 25 00, Fax. 013-36 25 10

BIKE Trollhättan AB, Trollhättan, Tel. 0520-700 75, Fax. 0520-762 84

Stötdämparexperten AB, Stockholm, Tel. 08-650 10 07, Fax. 08-650 10 09

Schneiders MC AB, Upplands Väsby, Tel. 08-590 310 80, Fax. 08-590 725 53

MB Racing AB, Västerås, Tel. 021-81 17 77, Fax. 021-81 17 78

Revelj Racing, Hede, Tel. 0684-120 59, Fax. 0684-122 75

Two Wheels I Umeå AB, Umeå, Tel. 090-187 595, Fax 090-18 77 61

Heds Motor AB, Boden, Tel. 0921-175 10, Fax.0921-162 20

Traction, handling,
comfort and safety



ADVANCED SUSPENSION TECHNOLOGY

Öhlins Racing AB, Box 722, S-194 27 Upplands Väsby, Sweden.

Phone +46 8 590 025 00, fax +46 8 590 025 80.

E-mail: info@ohlins.se